

YD Series three-phase pole-changing two-speed asynchronous Motor

Product Categories: **YD SERIES MOTOR**

Product Description:

Frame NO.: 80~180

Power: 0.45~12kW

Operation service: S1

Rated Voltage: $\pm 5\%$

Insulation class: B.F

Protection class: IP55

EFF: EF3 EF2 EF1

Ambient temperature:-15C~40C

Products Introduction:

YD series pole-changing multi-speed three phase induction motor are derived from Y2 series motors, it can change speed easily. speed of this series motor can be changed step by step according to the requirements of load characteristics, thereby reaching the air economizing on electricity and simplifying the system of speed variation.

This series of motor has great starting torque and low noise and vibration, and its mounting dimensions are complied with the standard of the International Electrotechnical Commission(IEC). used widely in the industrial departments of machine tools, chemical industry, textile, metallurgy and mine, printing, gearbox, agricultural machinery, etc

Technical Data-Y SERIES MOTOR

Y Y2 YS YD THREE PHASE MOTOR DIMENSIONS(mm)

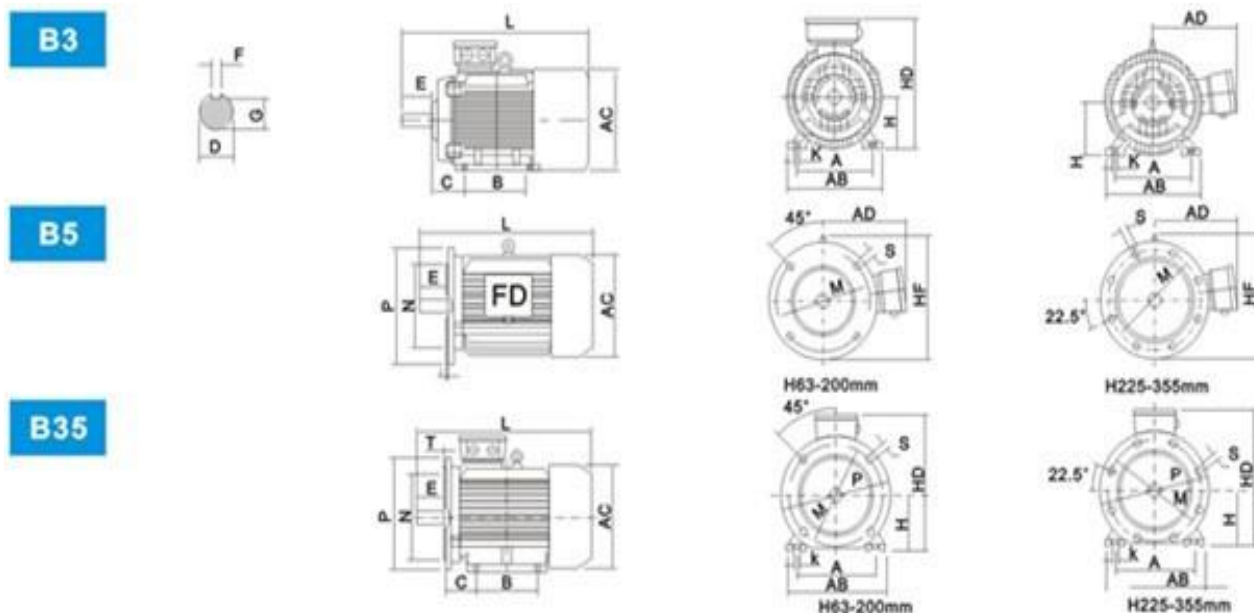

机座号 Frame No.	安装尺寸 Mounting dimension(mm)									凸缘号 Flange No.	B35 B5					外型尺寸 Overall dimensions≤						
	A	B	C	D	E	F	G	H	K		M	N	P	R*	S	T	AB	AC	AD	HD	L	DH
63	100	80	40	11	23	4	8.5	63	7	FF115	115	95	140	0	10	3	135	130	70	180	230	M4×12
71	112	90	45	14	30	5	11	71	7	FF130	130	110	160	0	10	3.5	150	145	80	195	255	M5×12

80	125	100	50	19	40	6	15.5	80	10	FF165	165	130	200	0	12	3.5	165	175	145	220	295	M6×16
90S	140	100	56	24	50	8	20	90	10	FF165	165	130	200	0	12	3.5	180	195	155	250	320	M8×19
90L	140	125	56	24	50	8	20	90	10	FF165	165	130	200	0	12	3.5	180	195	155	250	345	M8×19
100L	160	140	63	28	60	8	24	100	12	FF215	215	180	250	0	15	4	205	215	180	270	385	M10×22
112M	190	140	70	28	60	8	24	112	12	FF215	215	180	250	0	15	4	230	240	190	300	400	M10×22
132S	216	140	89	38	80	10	33	132	12	FF265	265	230	300	0	15	4	270	275	210	345	470	M12×28
132M	216	178	89	38	80	10	33	132	12	FF265	265	230	300	0	15	4	270	275	210	345	510	M12×28
160M	254	210	108	42	110	12	37	160	15	FF300	300	250	350	0	19	5	320	330	255	420	615	M16×36
160L	254	254	108	42	110	12	37	160	15	FF300	300	250	350	0	19	5	320	330	255	420	670	M16×36
180M	279	241	121	48	110	14	42.5	180	15	FF300	300	250	350	0	19	5	355	380	280	455	700	M16×36
180L	279	279	121	48	110	14	42.5	180	15	FF300	300	250	350	0	19	5	355	380	280	455	740	M16×36
200L	318	305	133	55	110	16	49	200	15	FF350	350	300	400	0	19	5	395	420	305	505	770	M20×42

B14

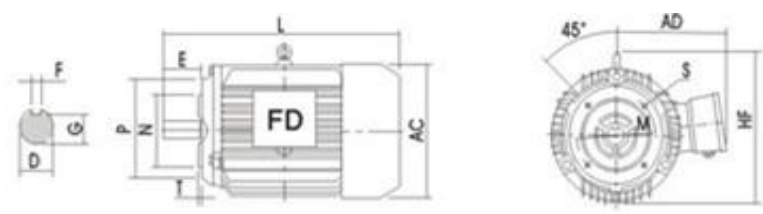

B34

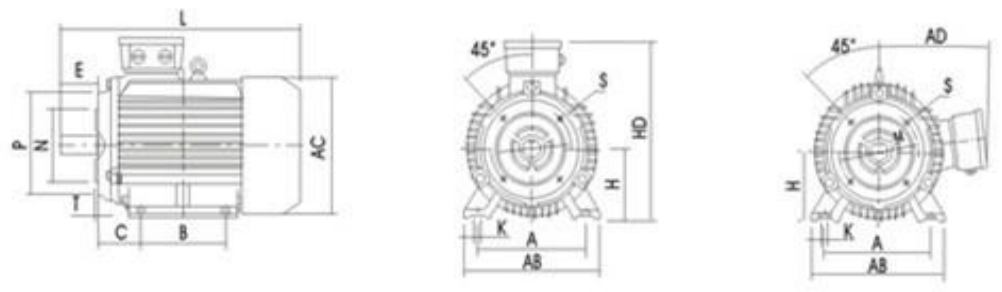

机座号 Frame No.	安装尺寸 Mounting dimension(mm)										凸缘号 Flange No.	B34 B14						外型尺寸 Overall dimensions≤					
	A	B	C	D	E	F	G	H	K	M		N	P	R*	s	T	AB	AC	AD	HD	L	DH	
63	100	80	40	11	23	4	8.5	63	7	FT75	75	60	90	0	M5	2.5	135	130	70	180	230	M4×12	
71	112	90	45	14	30	5	11	71	7	FT85	85	70	105	0	M6	2.5	150	145	80	195	255	M5×12	
80	125	100	50	19	40	6	15.5	80	10	FT100	100	80	120	0		3	165	175	145	220	295	M6×16	
90S	140	100	56	24	50	8	20	90	10	FT115	115	95	140	0	M8	3	180	195	155	250	320	M8×19	
90L	140	125	56	24	50	8	20	90	10	FT115	115	95	140	0		3	180	195	155	250	345	M8×19	
100L	160	140	63	28	60	8	24	100	12	FT130	130	110	160	0		3.5	205	215	180	270	385	M10×22	
112M	190	140	70	28	60	8	24	112	12	FT130	130	110	160	0		3.5	230	240	190	300	400	M10×22	

